

**UNIVERSITY COLLEGE TATI (UC TATI)****FINAL EXAMINATION QUESTION BOOKLET**

COURSE CODE	: DEE 3133
COURSE	: POWER ELECTRONICS & DRIVES
SEMESTER/SESSION	: 1 - 2023/2024
DURATION	: 3 HOURS

**Instructions:**

1. This booklet contains 4 questions. Answer **all** questions.
2. All answers should be written in answer booklet.
3. Write legibly and draw sketches wherever required.
4. If in doubt, raise your hands and ask the invigilator.

**DO NOT OPEN THIS BOOKLET UNTIL YOU ARE TOLD TO DO SO**

**THIS BOOKLET CONTAINS 8 PRINTED PAGES INCLUDING COVER PAGE**

**QUESTION 1**

a) Figure 1 shows a block diagram of a converting system using circuit 'X'.

- i. Identify circuit 'X' (1 mark)
- ii. Explain the function of circuit 'X' (2 marks)
- iii. Classify two (2) types of circuit 'X' (4 marks)

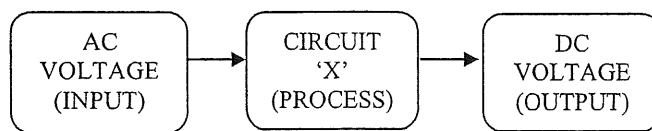

**Figure 1**

b) Base on table 1 below , draw the converter circuit for the criteria mentioned. (6 marks)

**Table 1**

<b>Type</b>	Controlled
<b>Supply</b>	Single Phase
<b>Output</b>	Full wave Bridge
<b>Load</b>	R

## POWER ELECTRONICS &amp; DRIVES (DEE 3133)

c) Figure 2 shows the circuit of half-wave with RL load and freewheeling diode. Given  $V_{supply} = 300 \sin 314 t$ ,  $R = 15\Omega$  and the inductor value is too large.

- i. Explain the circuit operation. (6 marks)
- ii. Describe the function of freewheeling diode in this circuit (2 marks)
- iii. Sketch the waveform of voltage input and output (8 marks)
- iv. Calculate average load voltage,  $V_{avg}$  (3 marks)
- v. Calculate Average load current,  $I_{avg}$  (2 marks)

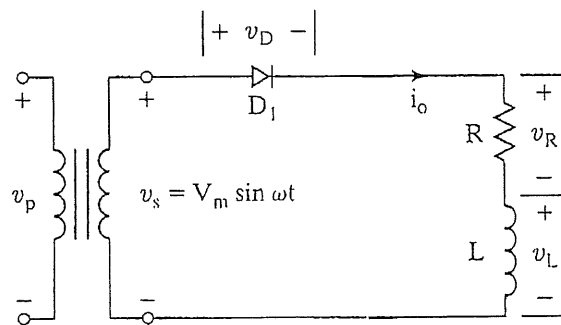

Figure 2

**QUESTION 2**

- a) Define DC Chopper (3 marks)
- b) Explain three (3) type of non isolated DC chopper topology. (6 marks)
- c) Sketch the circuit of boost converter during turning on and off condition. (4 marks)
- d) A buck converter is supplied from 25V battery source. Given  $L=400\mu\text{H}$ ,  $C=100\mu\text{F}$ ,  $R=20\text{ ohm}$ ,  $f_s=20\text{kHz}$  and  $D=0.6$ .
- Explain operation of the circuit during ON and OFF switching state complete with the circuit diagram. (10 marks)
  - Calculate voltage output produce by the circuit. (2 marks)
  - Sketch the waveform of voltage input and output (8 marks)

**QUESTION 3**

a) By referring to Figure 3 below :

- i. Name the inverter (1 mark)
- ii. State formula for  $V_{out}$  (1 mark)
- iii. Explain operation of the inverter circuit with R load (6 marks)
- iv. State three (3) basic type of switching scheme for this inverter (3 marks)

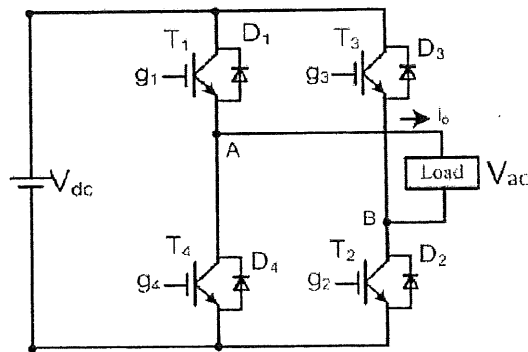
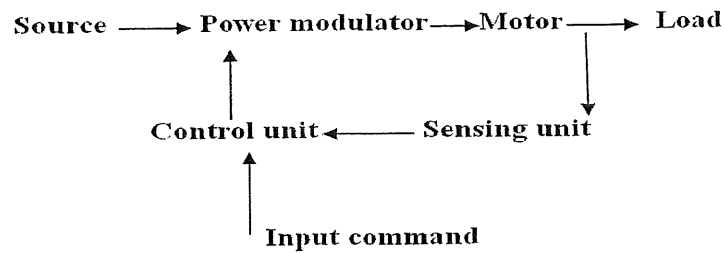

Figure 3

**QUESTION 4**

- a) Figure 4 shows the block diagram of electrical drive system.
- i. Give two (2) types of electrical drive (2 marks)
  - ii. State two (2) advantages of modern electric drive (2 marks)
  - iii. Explain any two (2) parts in the block diagram (6 marks)

**Figure 4**

- b) Explain operations of quadrant 1 and 3 in 4 quadrants mode of electrical motor including their application in real life. (6 marks)
- c) Explain methods to control the speed of series and shunt dc motor. (6 marks)

-----End of question-----

## LIST OF FORMULAS

Ohm's Law	$V = IR$
Uncontrolled rectifier	$V_{O_{avg}} = \frac{V_m}{\pi}$ $P_L = I_{rms}^2 R$ $V_{O_{rms}} = \frac{V_m}{2}$ $V_{O_{avg}} = \frac{V_m}{2\pi} * (1 - \cos \beta)$ $V_{O_{avg}} = \frac{2V_m}{\pi}$ $V_{O_{rms}} = \frac{V_m}{\sqrt{2}}$
Controlled rectifier	$V_{O_{avg}} = \frac{V_m}{2\pi} * (1 + \cos \alpha)$ $P_L = I_{rms}^2 R$ $V_{O_{rms}} = \frac{V_m}{2} \sqrt{1 - \frac{\alpha}{\pi} + \frac{\sin(2\alpha)}{2\pi}}$ $V_{O_{avg}} = \frac{2V_m}{\pi} * (\cos \alpha)$
DCchopper	$P = IV$ $I_{Lmax} = V_o \left( \frac{1}{R} + \frac{(1-D)T}{2L} \right)$ $I_{Lmin} = V_o \left( \frac{1}{R} - \frac{(1-D)T}{2L} \right)$ $V_o = D(V_{in})$ $V_o = \left( \frac{V_{in}}{1-D} \right)$

## POWER ELECTRONICS &amp; DRIVES (DEE 3133)

	$\Delta V_o = \frac{V_o(1-D)T^2}{8CL}$ $\Delta V_o = \frac{V_o DT^2}{RC}$ $r = \frac{(1-D)T^2}{8CL}$ $r = \frac{DT^2}{RC}$ $I_L = \frac{V_{in}}{(1-D^2)R}$ $I_L = \frac{V_o}{R}$
<b>Voltage divider</b>	$V_x = \left(\frac{R_x}{R_T}\right) X V_S$
<b>Current divider</b>	$I_x = \left(\frac{R_T}{R_x}\right) X I_T$